

## Patios and Pergolas

Prior to the construction of a patio an application for a building permit must be lodged with, and approved by Shire's Building Services.

**Patio** – A patio is an unenclosed structure covered in a water impermeable material which may or may not be attached to a dwelling. Gazebo/thatch type structures are also considered to be a patio.

**Pergola** – An open sided structure used for shading and screening. Roof covering is limited to wide spaced battens, open lattice and/or pervious shade cloth.

A “minor” pergola less than 20m<sup>2</sup> in area and not exceeding 2.4m in height and/or a “minor” patio less than 10m<sup>2</sup> in area and 2.4m in height generally does not require a Building Permit providing it complies with the setback requirements below. Only one such “minor” pergola and/or patio is permitted on a lot without a Building Permit.

**Planning Approval** – Please check with the Shire of Murray's Planning Services before submitting a building application as some structures require planning approval and a building permit.

**Setbacks** - In residential areas, patios and pergolas generally can have their posts to the boundary. The roof cover may not project closer than 900mm to the boundary. On larger “Special Rural” or “Rural Residential” zoned land, all structures must be within the Building Envelope for the Lot, or setback in accordance with the requirements of the Town Planning Scheme No 4 (typically 20m for most Rural Residential lots). Supporting posts must be at least 1.8m away from leach drains and at least 1.2m away from septic tanks.

**Building Permit Application** - for a patio or pergola must be accompanied by:

1. A completed building permit application form, either a certified (BA1) or an uncertified (BA2) signed by the builder.
2. One copy of a site plan, indicating the location of the proposed building, any existing buildings on site and the location of the septic system and leach drains if applicable. The Building Envelope must be delineated if applicable. All setbacks to boundaries, existing structures and the Building Envelope must be indicated on the site plan.
3. One copy of a floor plan indicating overall dimensions, spans, spacing's etc at a scale of 1:200.
4. One copy of a section detail drawing confirming the method of constructing the proposed building at a scale of 1:200. This detail will be required to be endorsed in ink by a professional engineer if the Patio or Pergola is greater than 6.0m in span or when the Building Surveyor considers that the proposed details may not be structurally adequate.

Details should include, but are not limited to, footing details and connection details confirming how the patio or pergola will be attached to any existing buildings.

5. Payment of application fees. Building fees are calculated on construction value with a minimum Shire fee of \$110.00 and a \$61.65 Building Services Levy.
6. Patios and Pergolas exceeding \$20,000 in value must be constructed by a registered builder OR an Owner Builder Approval issued by the Building Commission.

**For further information on Patios and Pergolas contact Shire's Building Services on 9531 7605.**

## Example Sheet

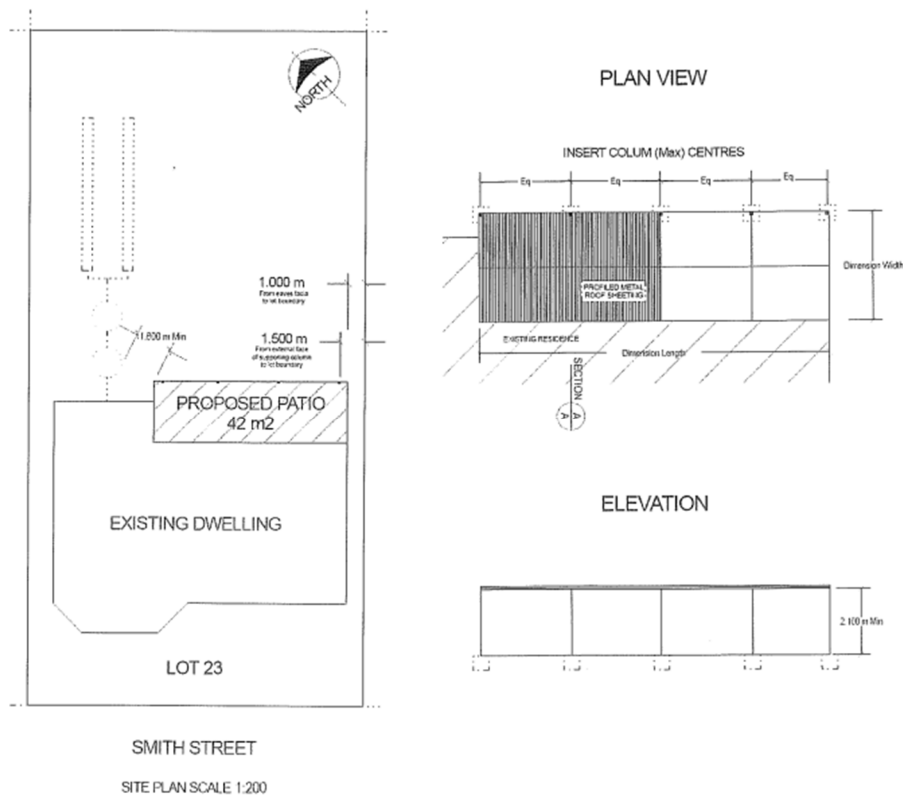

## Details that can be used for a Building Application

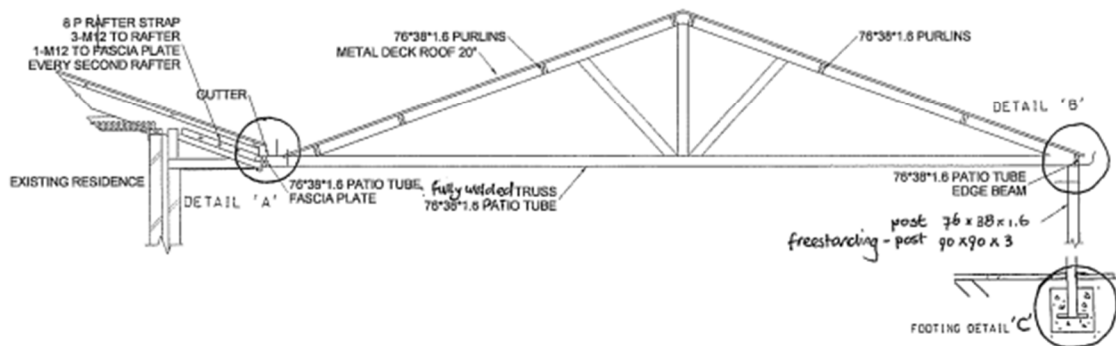
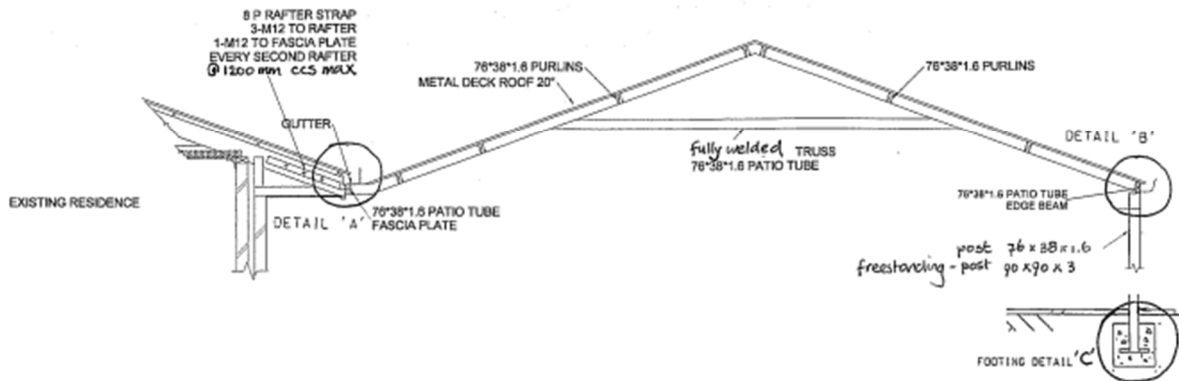

Steel truss design with a maximum span of 6m

Maximum spacing 3 m

## Details that can be used for a Building Application

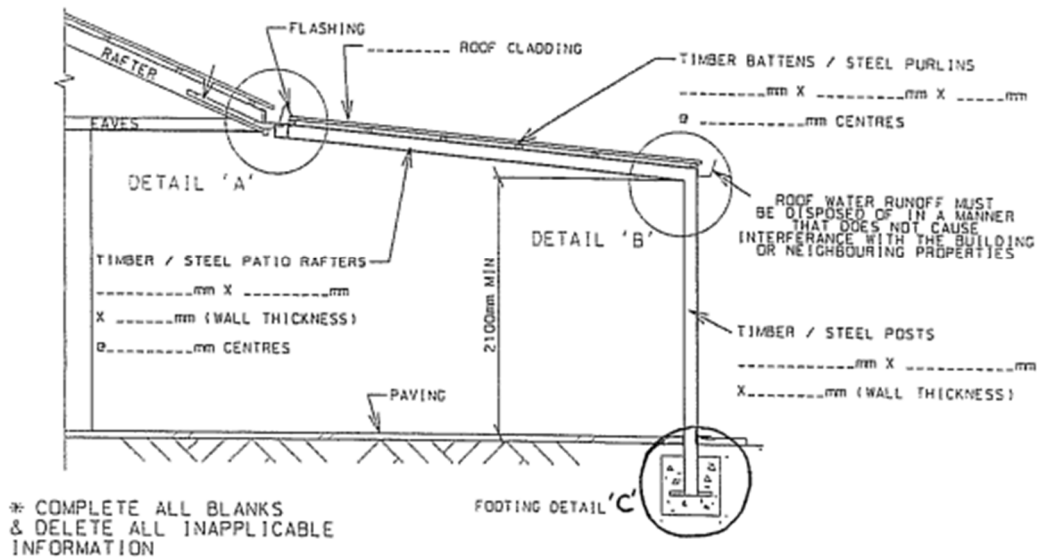

## Flat patio design with a maximum span of 6m

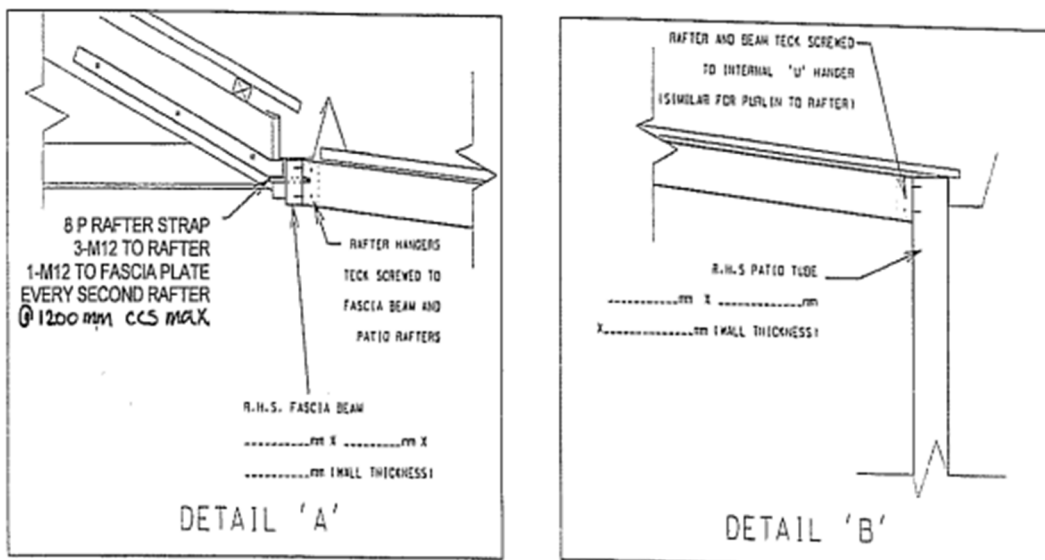

## Flat patio design with a maximum span of 6m Timber connection details

### Details that can be used for a Building Application

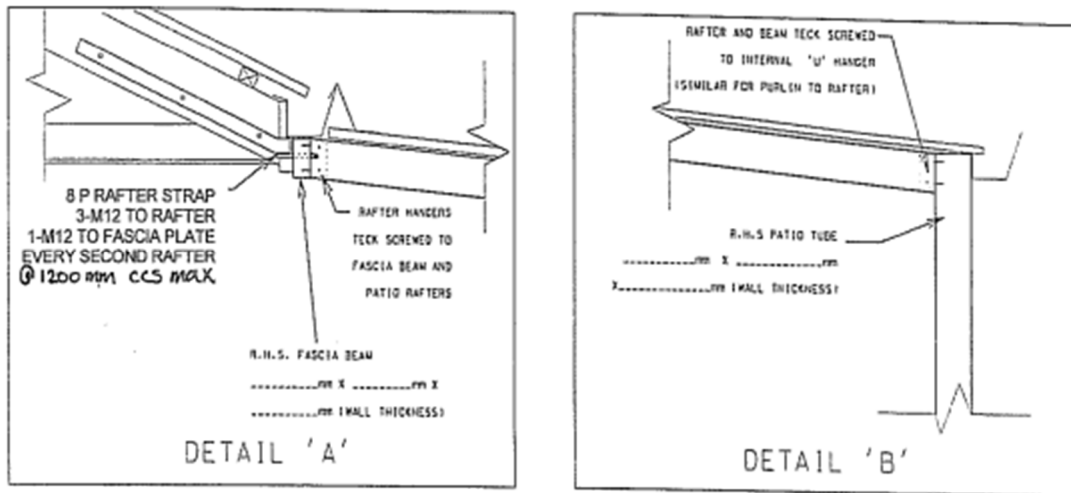

Flat/gable patio design with a maximum span of 6m – steel connection details – maximum post spacing 3 m

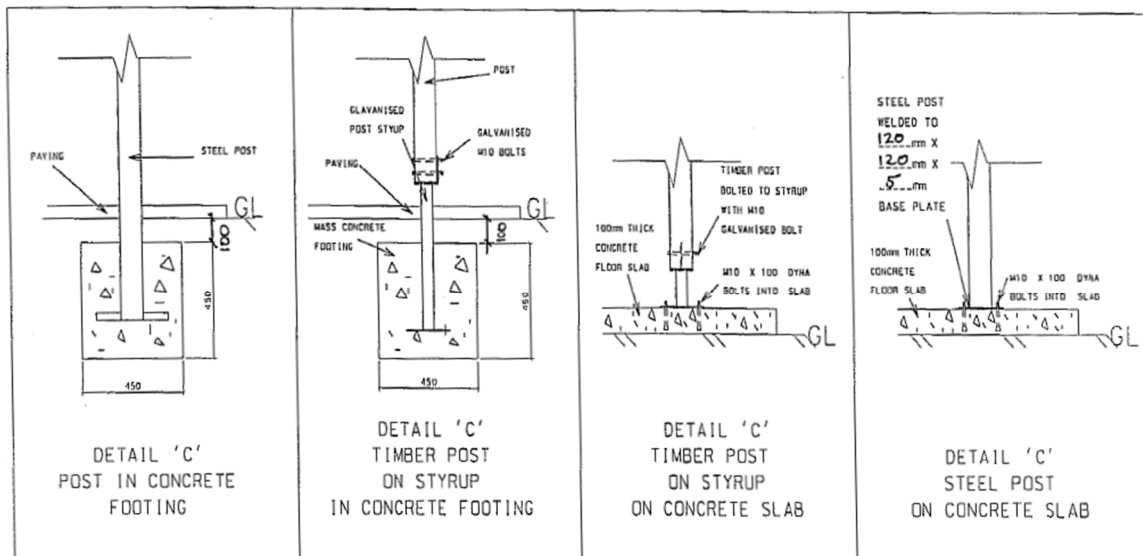

CROSS OUT INAPPLICABLE DETAILS

### Flat/gable patio design with a maximum span of 6m footing details